

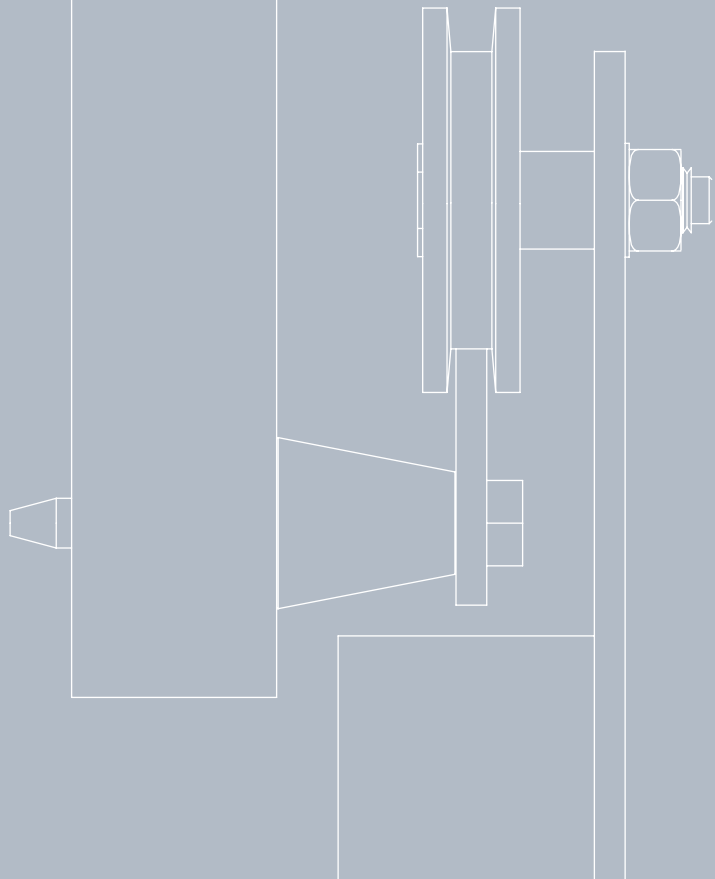

centor

A6 internal sliding system with exposed hardware



CONTENTS

Aesthetic Appeal	1
Considered Design	2
Creating With Centor	4
Architectural Detail	6
Component Selection	8
Installation	10

INTERNAL SLIDING SYSTEM WITH EXPOSED HARDWARE



AESTHETIC APPEAL

A6's classic open-rail design provides a rugged industrial look high on aesthetic appeal as well as robust functionality.

Fully exposed track and 75mm diameter grooved steel wheels give Centor A6 a rugged industrial look, with the classic open rail design widely specified as much for its aesthetic appeal as it's robust functionality.

Handling door panel weights up to 300 kilograms and dimensions as large as four by six metres with no diminution in performance from the precision ground bearings, A6 is serious hardware that doesn't mind taking its share of the spotlight!

A6 Specifications	
max panel weight	300kg
max door thickness	50mm
max panel height	4000mm
max panel width	6000mm



CONSIDERED DESIGN

Tracking

A6 carrier wheels run on lengths of tailor made 50mm x 6mm mild steel bar available with bright zinc plated finish, powdercoat, satin or bright chrome. Lengths up to six metres are produced in one piece while a bolted splice joins sections together for a longer rail. Side fixing holes are predrilled and safety stops at both ends of the track are standard.

Carriers

A6 carriers are available with the option of fastening to the top or the side of the door panel. In general panels over three metres wide will require three carriers for additional lateral support. The middle carrier should be positioned high so as to avoid it bearing any load.

DOOR PANELS TO 300KG & OPENINGS TO SIX METRES WIDE



Security

With sufficiently small top and bottom clearances allowed for, A6 can be secured against being lifted off the open rail track.

Warranty

Centor Architectural offers a 10 year warranty on its A6 hardware. Please see www.centor.com.au for more details.

Specifying EW

Architects and Designers can feel comfortable simply specifying "Centor A6" and leaving detailed component selection to the builder, joiner or fabricator.





DREW CARLING
MADDISON ARCHITECTS

CREATING WITH CENTOR

Centor speaks with director of Maddison Architects Drew Carling about the use of Centor A6 sliding hardware in the Leeda Developments offices.

Tell us about yourself and your practice.

I'm a director at Maddison architects. We are a small firm which focuses on providing 'tailor made' design solutions for our clients. Our work tackles most of the regular areas of architecture but we like to think that we find inspiration in each situation.

What do you like best about being an architect?

I'm always discovering things I don't know on projects that puzzle me.

What was your brief for the job?

We always feel honoured being asked by builders to work on their own projects and the Leeda Office's was special to us because our client Leeda Developments are responsible for building many of our projects over the years. Their brief called for an open space environment which could also be closed off to particular spaces and office's as needed.

Why did you decide to use A6 open rail doors?

For this project we liked the idea of using expressive construction techniques that allowed our client to showcase their skill and attention to detail. In the fit out the A6 seemed a natural fit to incorporate into the design.

What do you think the Centor Architectural systems added to this project?

The A6 gave us the necessary function and aesthetic we were looking for.

Has there been any feedback from the client regarding functionality of the hardware and the ease of operation?

Our client now inhabits a space which fits their functional needs and expresses their own attributes. The A6 contributes to this and our clients feedback is that they now invite new and existing clients and contractors to their office with renewed enthusiasm.



HIGH AESTHETIC
APPEAL WITH ROBUST
FUNCTIONALITY

ARCHITECTURAL DETAIL

Downloadable DXF or DWG files ready for use in your own documentation are a convenient resource for architects and specifiers wishing to use Centor systems.

A6 DXF or DWG files can be downloaded from www.centor.com.au

TOP FIX CARRIER

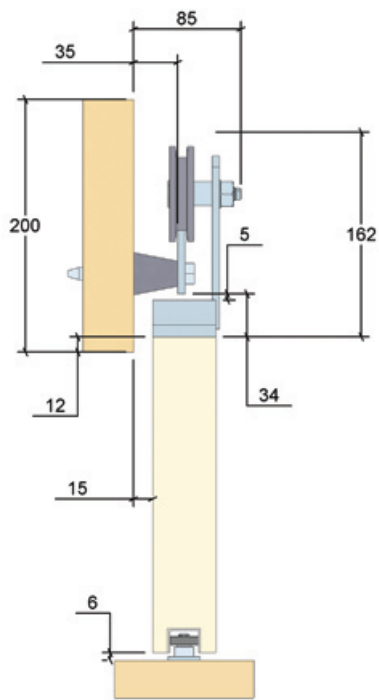

A6-001.DXF

FACE FIX CARRIER TO TIMBER HEAD

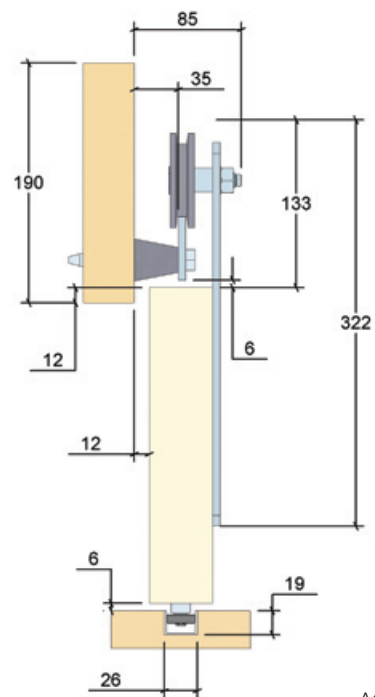

A6-002.DXF

FACE FIX CARRIER WITH GYPROCK WALLS

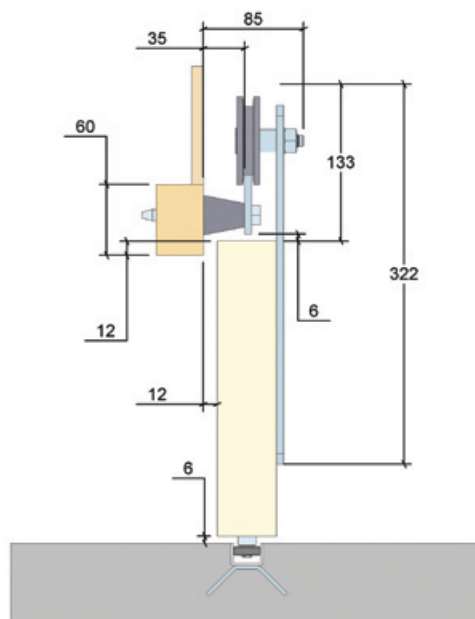

A6-003.DXF

ARCHITECTURAL DETAIL

TRACK

A6 tailor made track. Maximum 6m one piece.
Over 6m two pieces joined with splice bar.

L = track length including safety stops
HC = fixing hole centres, maximum 650mm centres

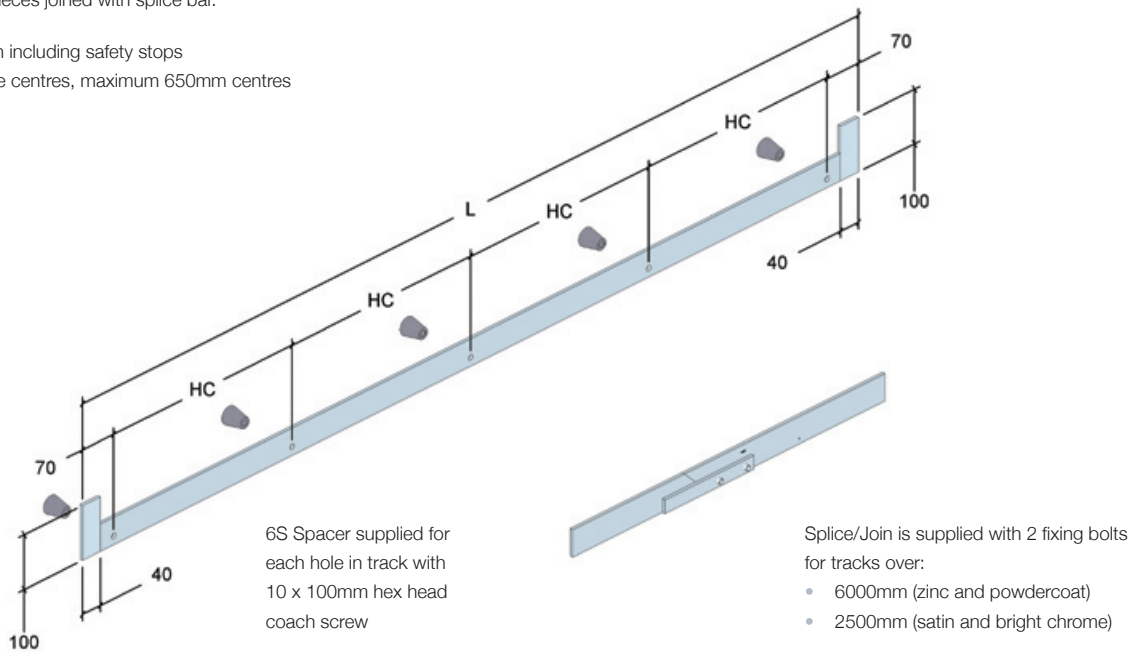

When ordering an A6 system track

- 1 Specify overall length of track including safety stops
- 2 Nominate if safety stops need to be welded at both ends, one only, or none at all
- 3 Advise finish required
- 4 Specify hole centres, maximum 650mm centres

Select finish required from

- zinc
- chrome
- satin chrome
- custom powdercoat

COMPONENT SELECTION

A6 is specified with 5 separate component groups. Components are required from each group to build an A6 sliding door system except when indicated otherwise.

- 1 Track* – choose surface finish, number of welded safety stops, spacer size and overall track size required to suit opening
- 2 Carriers – choose face-fix or top fix, surface finish and number required to suit panel layout
- 3 Guides – choose guiding method and number required to suit panel layout
- 4 Channel** – choose fixing type, surface finish and size required to suit opening
- 5 Door Stop – choose surface finish and number required to suit opening and panel layout

* Some tracks may require a splice/join please advise sales staff if this is of concern

** Channels are an optional item

GUIDES

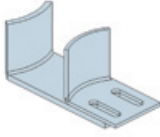
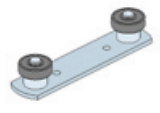
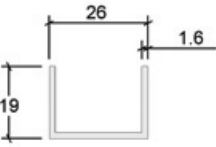
PART	SELECT GUIDE & CHANNEL	PRODUCT CODE	PART DESCRIPTION
	universal guide	UG	universal guide suits doors 32–54mm no groove required
	roller guide	ATFGD	double roller guide, stainless steel precision bearings 22mm diameter 1 per door
	extruded aluminium natural anodised	E2FCA2N	2000mm 19 x 26mm aluminium channel, natural anodised
		E2FCA3N	3000mm 19 x 26mm aluminium channel, natural anodised
		E2FCA4N	4000mm 19 x 26mm aluminium channel, natural anodised
		E2FCA6N	6000mm 19 x 26mm aluminium channel, natural anodised
	extruded aluminium gold anodised	E2FCA2G	2000mm 19 x 26mm aluminium channel, gold anodised
		E2FCA3G	3000mm 19 x 26mm aluminium channel, gold anodised
		E2FCA4G	4000mm 19 x 26mm aluminium channel gold anodised
		E2FCA6G	6000mm 19 x 26mm aluminium channel, gold anodised
	extruded brass	E2FCB2	2000mm 19 x 26mm brass channel
E2FCB3		3000mm 19 x 26mm brass channel	
E2FCB4		4000mm 19 x 26mm brass channel	
E2FCB6		6000mm 19 x 26mm brass channel	



Custom powdercoat available on request

COMPONENT SELECTION

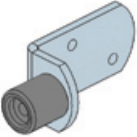
DOOR STOP

PART	PRODUCT CODE	PART DESCRIPTION
	6WS	large wall stop, zinc used to limit door travel in either direction

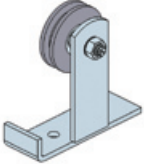
CARRIERS

PART	SELECT CARRIER	PRODUCT CODE	PART DESCRIPTION
	top fix*	6CCT	top fix carrier, 75mm diameter, zinc
		6CCTC	top fix carrier, 75mm diameter, chrome
		6CCTPC	top fix carrier, 75mm diameter, custom powdercoat
		6CCTSC	top fix carrier, 75mm diameter, satin chrome
	face fix*	6CCS	face fix carrier, 75mm diameter, zinc
		6CCSC	face fix carrier, 75mm diameter, chrome
		6CCSPC	face fix carrier, 75mm diameter, custom powdercoat
		6CCSSC	face fix carrier, 75mm diameter, satin chrome

* Specify 2 per door or 3 carriers for doors 3000mm wide

INSTALLATION

Before starting any installation, ensure the head (lintel) is sufficiently strong and rigid. It is important that the track be fitted straight and parallel to the head.

Fit track to head horizontally, using coach screws in all holes provided. Underside of track for top fix carriers should be 34.0mm above the under side of the doorway head (refer A6-001.DXF).

For side fix carriers, this dimension is 18.0mm (refer A6-002.DXF).

Install track to permit traverse of door to cover the opening.

For Top Fix carrier, attach to top of door with 10mm x 50mm coach screws with carrier bracket flush with either end of door stiles. Hook wheels over track and hang door vertically.

For Side Fix carrier, position the door on packers so the top of the door is 6mm below the track. Hang the carrier on the track, and position for fixing to the door where required. Mark the door at the centre of the fixing slot. Drill a 10mm hole and insert the cup head bolt with the head between the door and the wall. Fit and tighten nut and washer, securing the bracket to the door. Check the door operation, and closure to jamb before fixing the bracket with countersunk wood screws.

Install UG Universal Slipper Guide as shown on the next page so that the door hangs vertically under the track.

An alternative is a channel and roller guide (illustrated over). For either method, check guides do not project past the end of the door at each end of the travel. If necessary, adjust door stops.

Fit door stops to retain door at each end as needed.

Finish by fitting Flush Pulls or Dropbolts.

TOP FIX CARRIER WITH TRACK, WELDED SAFETY STOP,
DOOR STOP WITH BUFFER, SPACER AND COACH SCREW

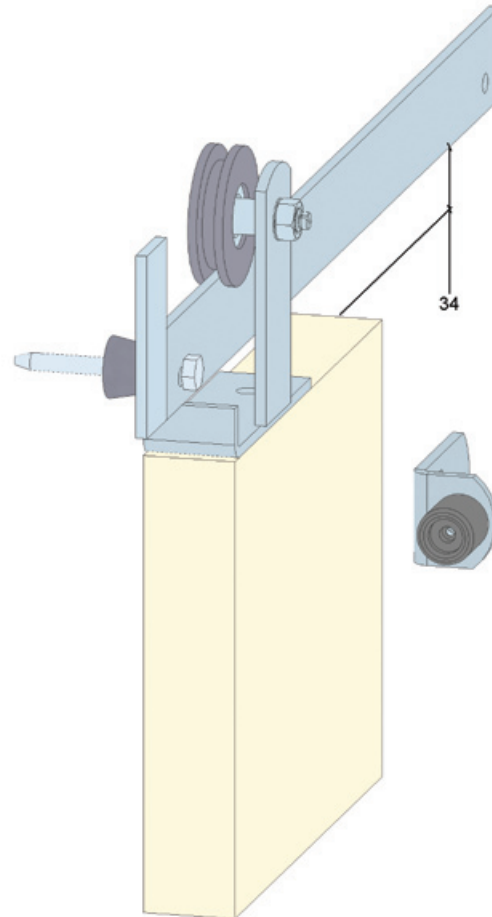

GAP FOR NOMINAL 50MM DOOR

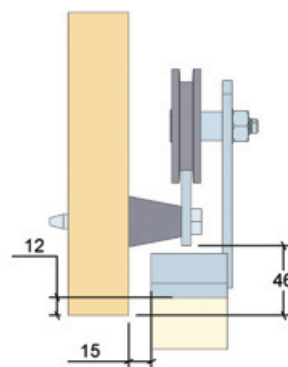

A6-004.DXF

INSTALLATION

NON-GROOVED DOOR WITH
UNIVERSAL GUIDE

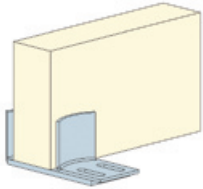

UG Universal slipper guide

TIMBER FRAMED DOOR WITH ROLLER
GUIDE AND CHANNEL

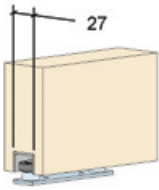

E2FCA aluminium or E2FCB brass floor channel
ATFGD double roller guide

SIDE FIX CARRIER, TRACK, WELDED SAFETY STOP
DOOR STOP WITH BUFFER, SPACER AND COACH SCREW

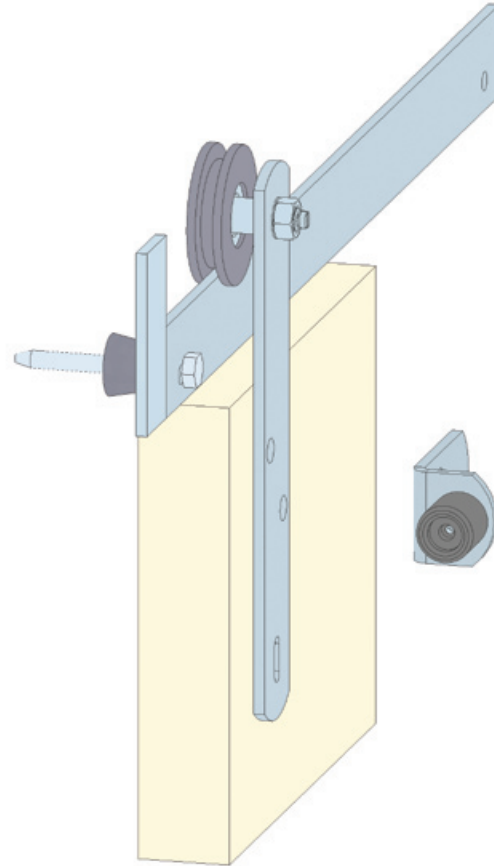

GAP FOR NOMINAL 50MM DOOR

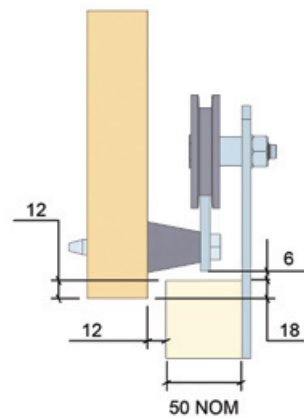

A6-005.DXF

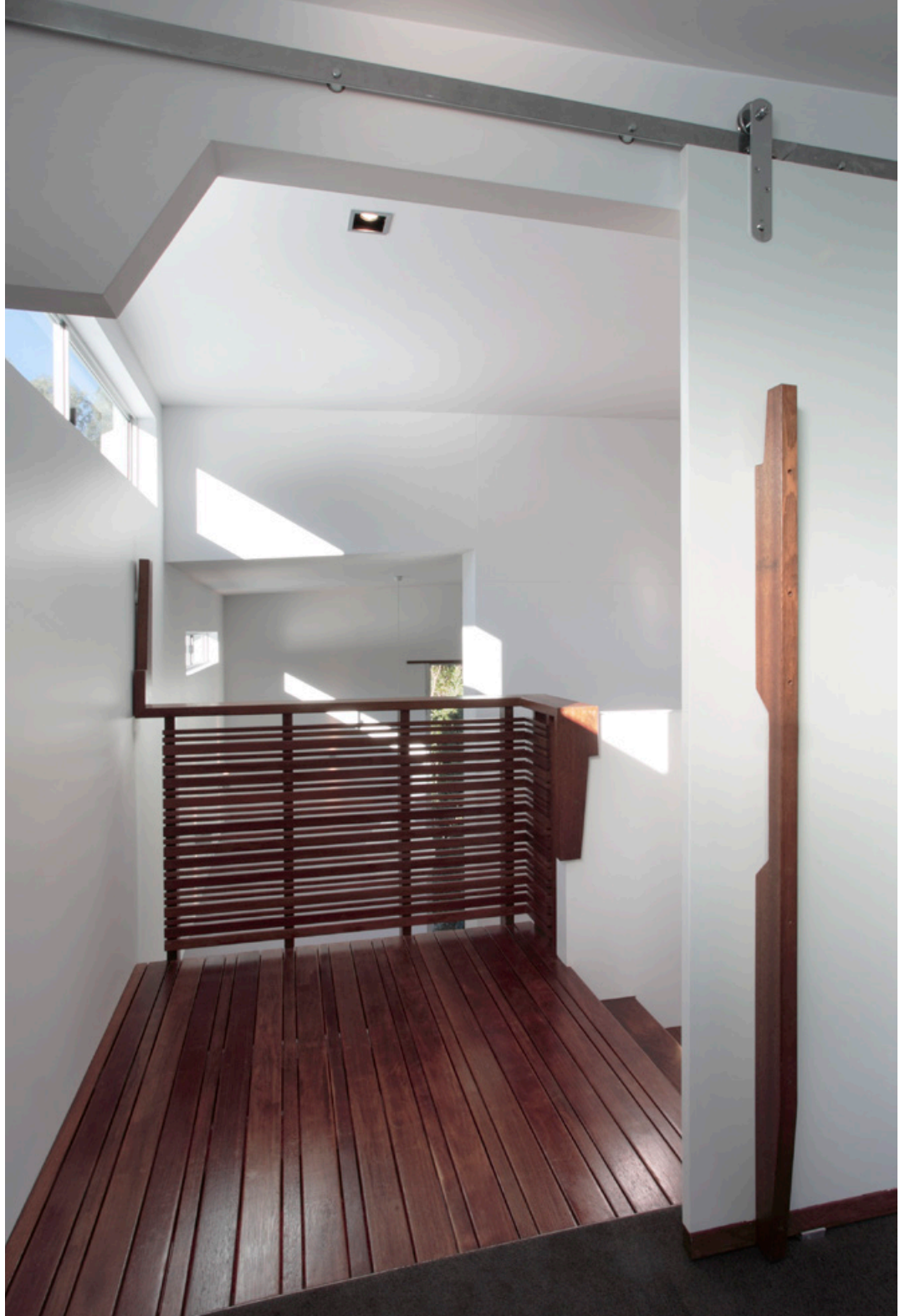

CARRIERS FASTEN TO
THE TOP OR SIDE OF
DOOR PANELS

While every effort has been made to ensure the accuracy of the information in this publication, Centor Architectural assume no responsibility for errors or omissions or any consequences of reliance solely on this publication.



Centor Australia Pty Ltd

ABN 96 009 716 189
telephone 1300 CENTOR
1300 236 867
facsimile 1300 CENFAX
1300 236 329
mail@centor.com.au
www.centor.com.au

BRISBANE

Centor Australia Pty Ltd
Head Office & Factory
997 Kingsford Smith Drive
PO Box 1550
Eagle Farm QLD 4009
telephone +61 7 3868 5777
facsimile +61 7 3868 1201

SYDNEY

Centor Australia Pty Ltd
6/33 Heathcote Road
Moorebank NSW 2170
telephone +61 2 9765 4200
facsimile +61 2 9824 3469

MELBOURNE

Centor Australia Pty Ltd
28 Keysborough Close
Keysborough VIC 3173
telephone +61 3 9709 0300
facsimile +61 3 9798 1645

ADELAIDE

Centor Australia Pty Ltd
Unit 4, 2 Endeavour Drive
PO Box 285
Port Adelaide SA 5015
telephone +61 8 8304 2577
facsimile +61 8 8304 2599

PERTH

Notchka Pty Ltd
45 Colray Avenue
Osborne Park WA 6017
telephone +61 8 9443 3266
facsimile +61 8 9443 3250
notchka@norcom.net.au

TASMANIA

Launceston
Access Hardware Pty Ltd
42 Invermay Road
Mowbray Heights TAS 7248
telephone +61 3 6331 2533
facsimile +61 3 6331 2733
accesshw@bigpond.net.au

Hobart

Access Hardware Pty Ltd
21 Brisbane Street
Hobart TAS 7000
telephone +61 3 6231 9926
facsimile +61 3 6231 9927



216-100-030-001