



Astragals

(Meeting Stile Seals)

RP85



A magnetic seal that is fixed to the head and jambs as a door stop where steel clad doors are used. For timber doors, a thin steel strip can be attached to the door face. The magnetic strip has sufficient closing strength that latches are not required.

Note: If fixing to rebated frames of single doors, specify a long backset door latch.

Location

Head and Jamb for single and double broad butt hinged doors.

Min/MaxGap

0 - 4mm (user determined).

Seal Sizes Available in stock lengths.

Standard Finish

Aluminium anodised 15 microns. Satin Clear (Silver) or Bronze finish.

P.E. Paint (extra cost). Is a two pack polyester enamel colour match finish which is equal to or exceeds powdercoat finish.

Fixing Method

Zinc plated, cross recess head S.T. screws of the appropriate size are supplied.

Seal Material

PVC (charcoal).

Used in conjunction

Door bottom seals and astragal seals.

Approvals

Acoustic AUS/NZ: Conforms to BCA Sec. F5.5 Tested to AS 1191, AS 1045, AS/NZS 2176.

UK/EU: Conforms to Approved Document E. Tested to BS EN ISO 140.3 (similar to BS EN ISO 717.1, BS 2750, BS 5821).

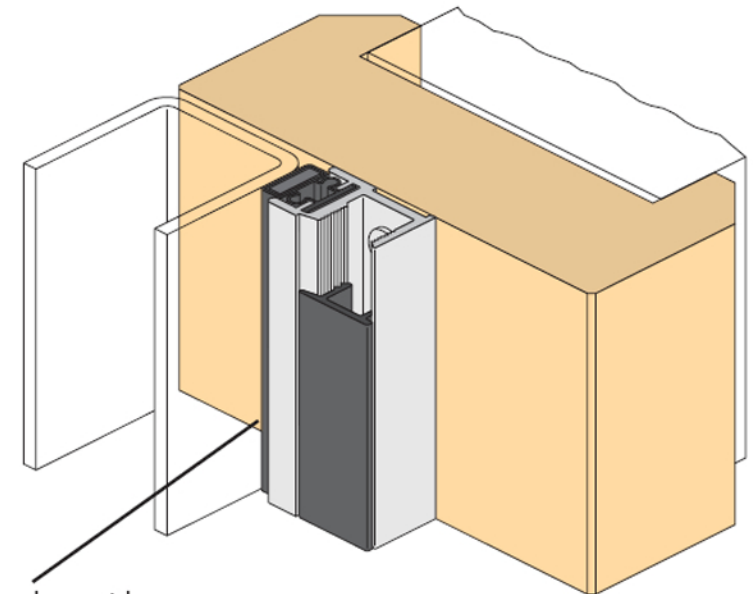
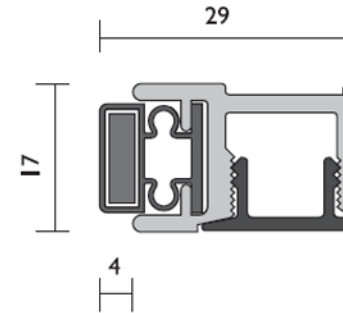

Timber door with steel insert (By others)