

E3 HARDWARE SYSTEM



E3 bifold door hardware for panels up to 115kg

centor®

ENGINEERED EXCELLENCE

One moment bifolding doors are acting as an effective, secure barrier from rain, wind and noise. The next they're effortlessly moved aside to reveal wide open space – with no fixed glass panels or posts.

E3 can be relied upon to add flair and flexibility to the widest range of applications, from private residences to the most ambitious store front, restaurant or commercial project. The considerable weight-bearing capacity of the elegant, precisely functioning E3 ensures that possible applications for Centor's bifold range are limited only by the imaginations of the world's most progressive architects and designers.

Engineered to withstand the most severe weather, E3 is just as suited to interior use where the ability to visually and physically connect spaces can be just as beneficial and the sound-proofing effect of double-glazing just as important. The benefits to the end-user in flexibly managing interior or exterior space to suit lifestyle or business are literally changing the face of contemporary building design.



E3 Specifications	
max opening width	19200mm
max panel weight	115kg
max panel height	3600mm
max panel width	1200mm
min panel thickness	35mm
max number of panels	16 (8 each direction)





flexibly manage space in a
WIDE RANGE OF APPLICATIONS

CENTOR HARDWARE FOR DOORS THAT GLIDE OPEN AND SLIDE SHUT



High performance results

Internal environment, operational function, durability; painstaking attention to detail and an unerring commitment to quality mean 'Centor-grade' performance, whatever the category. The result is a degree of control and comfort for the end-user that matches the easy flexibility of modern design.

Rain and wind

Centor hardware was utilised in the first tracked bifolding door system to be certified under Australian Standard AS2047, which specifies the weather performance required of external windows and sliding doors. Doors installed with Centor E3 and E4 folding systems have also been certified to stringent Miami-Dade County hurricane standards, the toughest testing anywhere in the world. With impressive water performance ratings achievable from both outward and inward opening doors, driving rain and howling gales can be shut out completely.

Air infiltration

The E3 system achieves its superior rain and wind resistance in part from the way it allows the folding doors to close snugly against weatherseals. In the same way doors using E3 effectively resist air infiltration to a level up to 50 times better than a sliding door.

Noise and temperature

With double glazing allowed for by E3's impressive panel weight capacity, unprecedented levels of insulation against noise and temperature variation are possible.

Assembly and Installation

With quick-fix surface-mounted fittings assembly and installation couldn't be easier. Comprehensive instructions are included and drill jigs are available to ensure precise placement of fittings.



Effortless operation

While E3's outstanding performance as part of a secure, weatherproof barrier is crucial, it's not until the doors are opened that the space-transforming benefits of the system truly come into play. For maximum enjoyment and use of the system, every effort has been made to ensure that doors glide open and slide shut with the minimum of effort – and that they continue to do so.

Quality manufacture, clever design

E3 carriers, guides and pivots use high grade stainless steel bearings custom machined to extremely fine tolerances on state-of-the-art German and Swiss machinery – a minimum of five bearings to each carrier. Machined wheels are individually precision ground to an ultra-fine hone. Clever carrier design prevents scraping on the inside of the overhead track. A polypropylene floor channel lining adds to the smooth, almost silent rolling action which brings a smile to the face of the user!

Adjustment

While E3 is designed to operate flawlessly well into the future, built-in adjustment mechanisms make the system tolerant of an imperfect world. Surelock 5 Centor's patented carrier pin locking system ensures that once heights are set they stay set. However should door panels swell or a newly built structure settle over time, the end-user can easily make vertical and lateral adjustments simply using a screwdriver or allen key.

Collaborative design process

E3's thoughtful design doesn't achieve the highest performance in all categories on its own. It's in its element teamed with the quality products created by Centor's many manufacturing and custom fabricating clients. The Centor technical department can assist in the design process for door sets incorporating the E3 system to ensure that the highest criteria for completed and installed doors are met even in the most unusual applications.

EXTENSIVE TESTING ENSURING YEARS OF TROUBLE-FREE USE



Proven durability

In addition to extensive weather testing as part of complete door systems, all individual E3 components have been extensively laboratory tested, ensuring years of trouble-free enjoyment from hardware which ages with grace.

Cyclic Testing

E3 has undergone Centor's minimum requirement of cyclic testing for an equivalent 40 year period. Many individual components are rated to over 100,000 cycles.

Corrosion testing

Stainless steel, PVD Brass, anodised aluminium and engineering-grade plastics are used throughout the E3 system and are carefully selected to maximise performance in any environment. Centor conducts regular, thorough corrosion testing in a salt spray chamber, fixing hardware to various substrates to ensure that E3 will perform admirably even in the most exposed of coastal applications.

Structural testing

Structural proof load tests up to 3300 Pa have been achieved by maximum size doors using E3 system. E3 hardware components have been load tested to 3KN in accordance with AS/NZS1170.0.

Finite element analysis

Finite Element Analysis (FEA) is a computerised simulation technique where products are exposed to virtual operating environments and accurate predictions made in terms of load and deflection. Centor undertakes FEA in the design process to ensure the best balance of performance, cost and materials in every system.

Hurricane testing

In the course of obtaining approval under the stringent Miami-Dade County testing regime, doors based on the larger E4 system were subjected to structural wind load testing over some 9000 cycles (4500 positive, 4500 negative). Taking nearly eight hours this process thoroughly examines door system integrity. Small and large missile impact testing was also performed along with exacting testing for wind, water and air infiltration as part of the single toughest testing process anywhere in the world. Utilising the same technology and based on the same functional geometry as the E4 system, E3 will take the most extreme conditions in its stride.

PAIR E3 BASED DOORS WITH THE AWARD WINNING CENTOR S4 SCREEN



E3 up close

Even a casual glance at the E3 system gives a strong impression of Centor's commitment to quality, but it's only upon closer inspection that the attention to detail really becomes apparent. Stacked with standard features and with an abundance of options to choose from, Centor E3 looks even better up close!

Materials and finishes

E3 carriers, guides, pivots and hinges are available in stainless steel brushed and PVD Brass or PVD Bronze over stainless steel. Head tracks, floor guide channels and sills are available in gold or natural anodised finish, and custom powder coat.

Panel size and materials

Centor's innovative hinge system enables the use of uniform-sized door panels regardless of the door configuration ensuring maximum efficiency in door manufacture. Easily installed hardware can be teamed with door panels in timber, aluminium, PVC or fibreglass.

Design features

A floating wall pivot is used to control door stile deflection and bowing on tall doors caused by wind loads or climatic conditions. Offset floor guides and floor pivots allow the guide channel to be concealed under the doors when they are closed. Straight guide option is also available. Top-rolling function means performance is never compromised by refuse in tracks.

Dropbolts

Easily installed with a dedicated router bit available from Centor, DF and DO dropbolts are available in a range of lengths and finishes to suit every E3 application. Available keyed and non-keyed, the clean-lined DF and DO dropbolts anchor doors firmly in the closed position and, together with the weather seals, eliminate rattling in strong winds.

Centor screening

The award-winning S4 or S2 is the latest innovation from Centor. Available as an insect screen or thermal control blind up to 3 metres high and 9.1 metres wide, S4 or S2 is perfect to use with E3-based doors.

RANGE OF FEATURES ALLOW E3 TO BE UTILISED WITH CONFIDENCE



E3 assurance

If success in modern design can be measured by the degree of comfort and ease afforded to the end-user, then Centor E3 again rates highly. E3's superior function and performance goes a long way to creating a relaxed setting, while a range of other measures allow the system to be utilised with complete confidence.

Unparalleled security

The E3 system responds to an increasingly security conscious market place with measures designed to ensure unwanted visitors are excluded – as well as the elements.

Concealed fittings

When doors utilising E3 are closed there are no externally accessible parts that can be removed or damaged. Screw fixings are concealed and hinge caps are retained by hidden fasteners.

Locking screw technology

The E3 system incorporates locking screw technology which ensures the E3 hardware can not be removed from the track when the doors are closed.

Warranty

In line with a commitment to the highest possible quality Centor offers a 10-year warranty on all E3 hardware. For full details refer to the current Centor Catalogue, or view information online at centor.com.

Specifying E3

E3 is a fully integrated system suitable for applications up to 115 kilograms per panel in timber, aluminium, PVC or fibreglass. Architects and specifiers should feel comfortable simply specifying 'Centor E3' and leaving detailed component selection to the builder, joiner or fabricator.





E3 PRODUCT DETAILS

Downloadable DXF or DWG files ready for use in your own documentation are a convenient resource for architects and specifiers wishing to use Centor systems.

E3 DXF or DWG files can be downloaded from centor.com

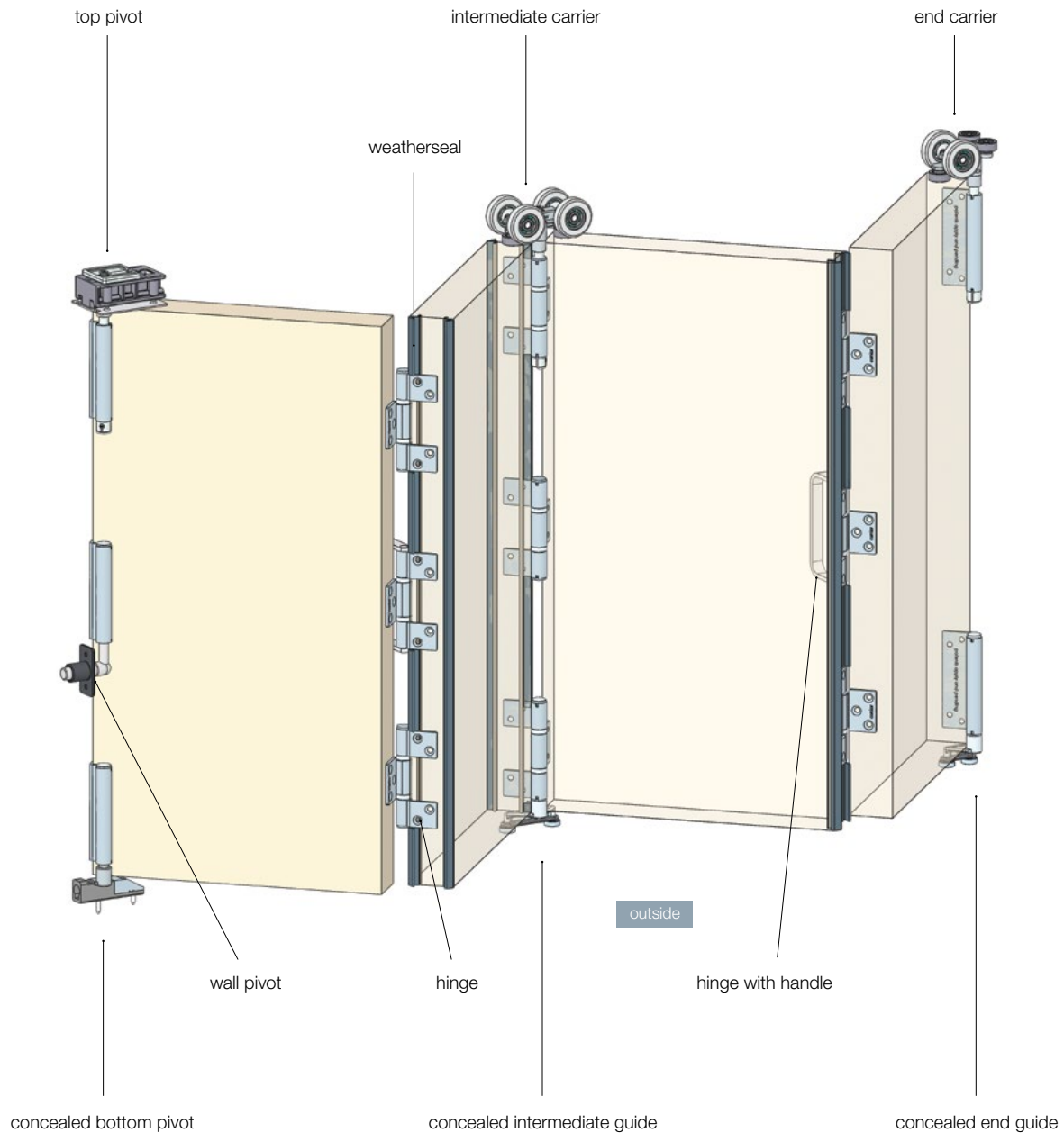

ARCHITECTURAL DETAIL

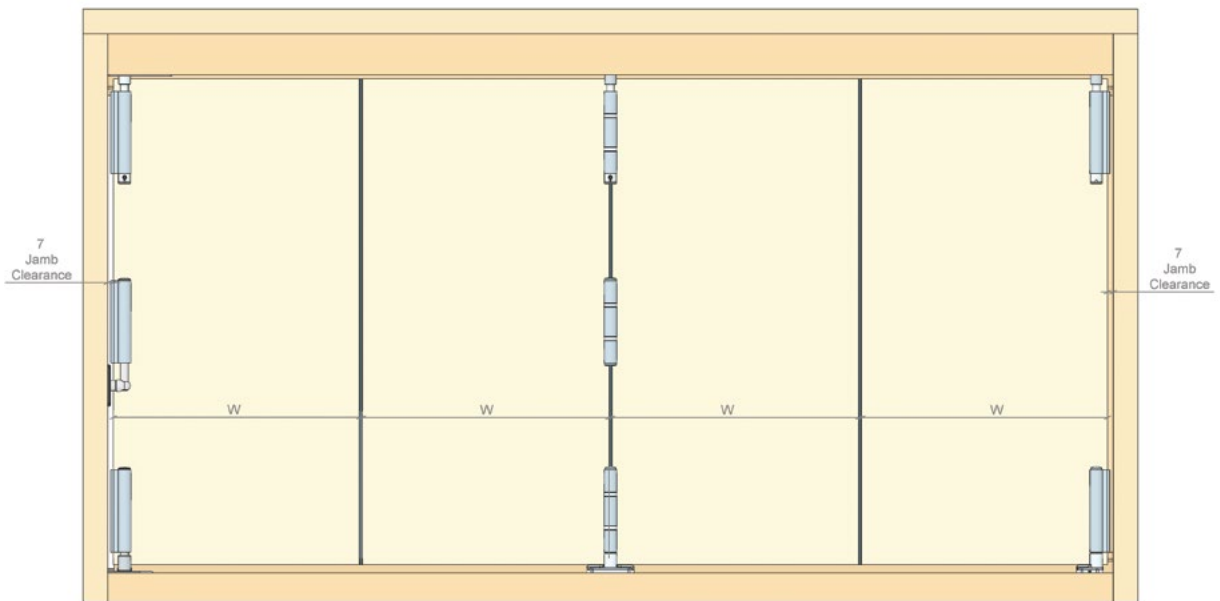
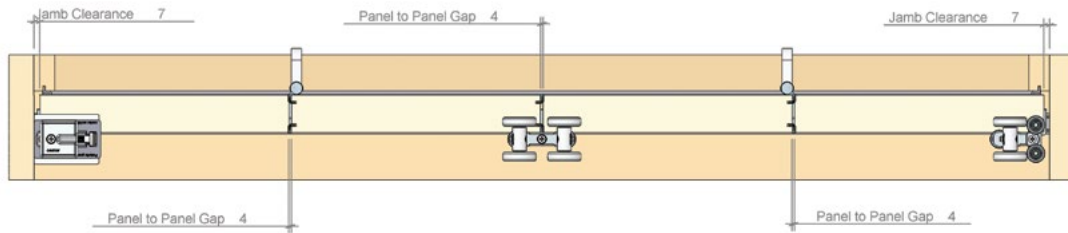

ARCHITECTURAL DETAIL

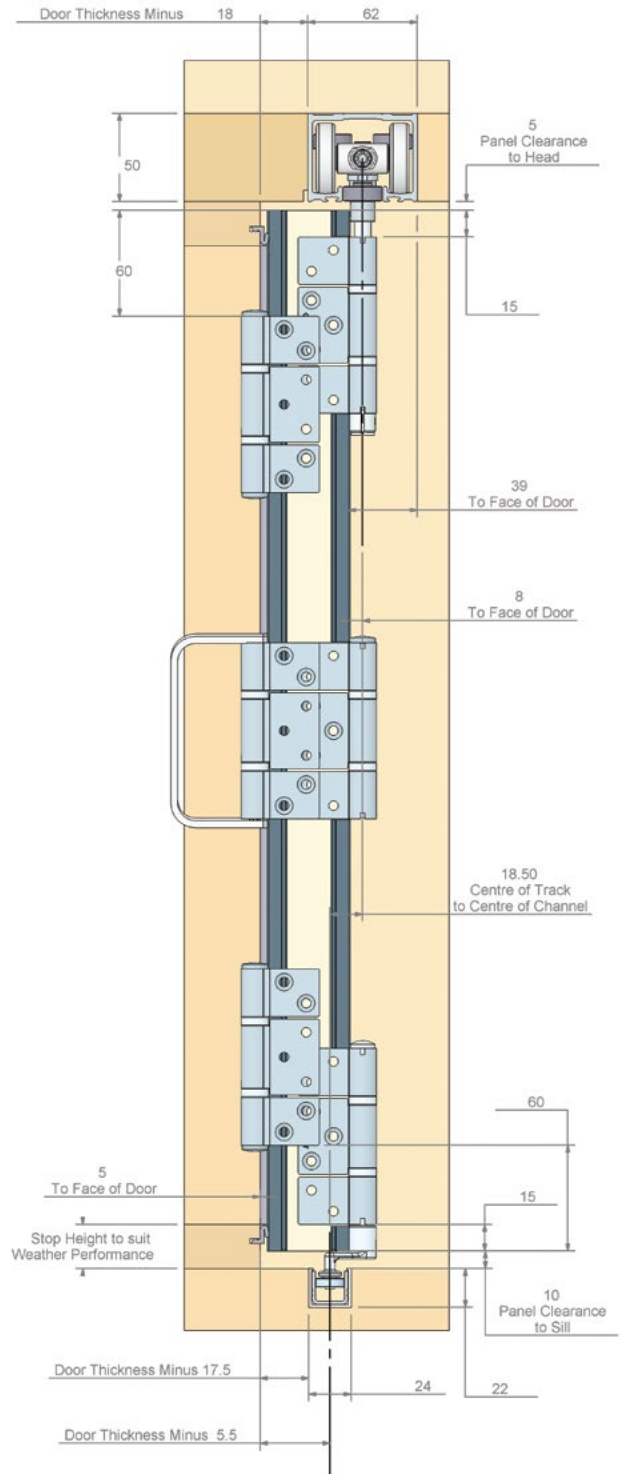
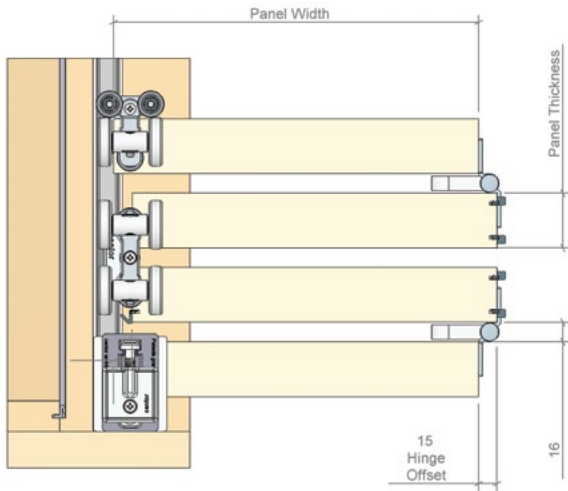

ARCHITECTURAL DETAIL

Concealed sill installation details

(Outward with 40mm door panel shown)

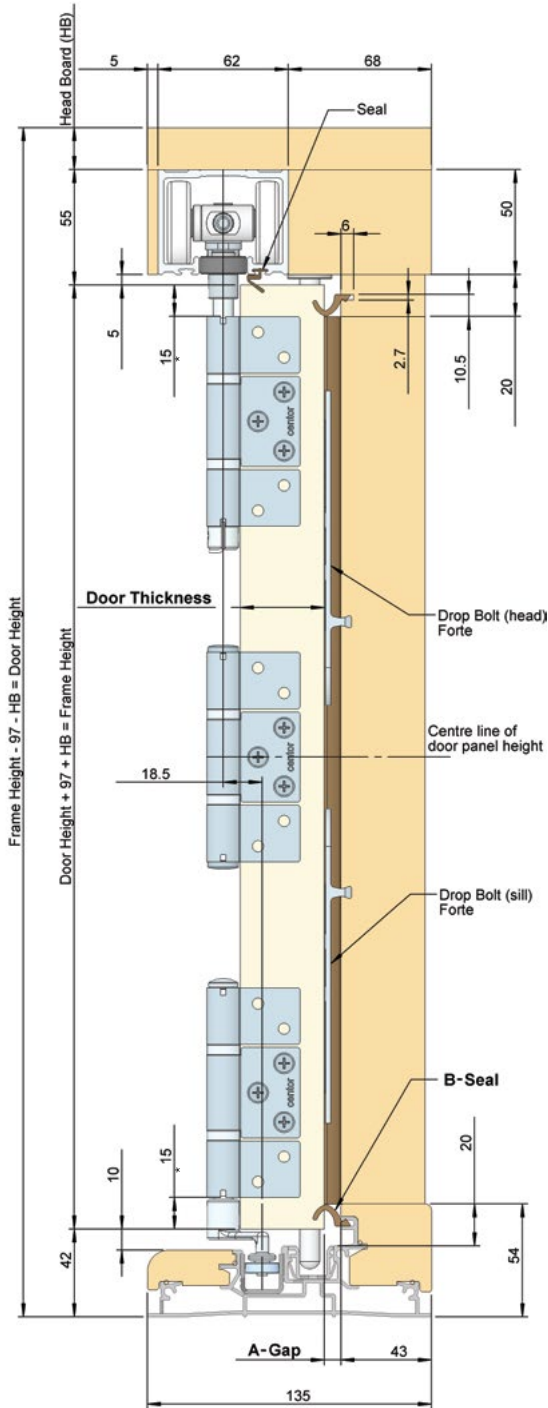

* 15mm for pivot, intermediate and left-hand and right-hand carrier sets.

Concealed narrow sill installation details

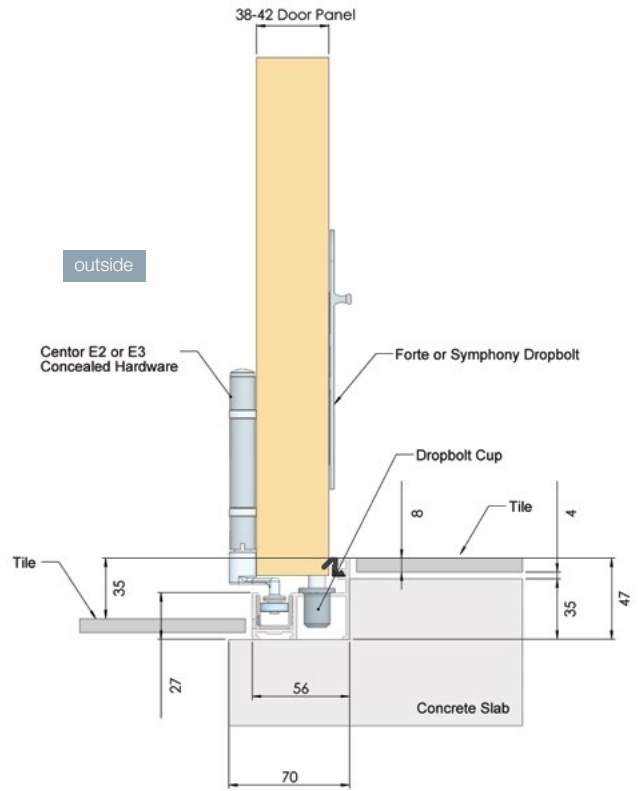

Ready-made style!

Centor's ready-made Door Sill systems dramatically simplify the installation of bifold doors in exposed applications and ensure a stylish, effective result. Integrating Centor floor guide channels provision for straightforward dropbolt placement and ingenious solutions to the issue of floor-channel drainage, Centor Door Sills fit neatly into place between door jambs with the minimum of fuss.

ARCHITECTURAL DETAIL

Inward concealed guide sill details

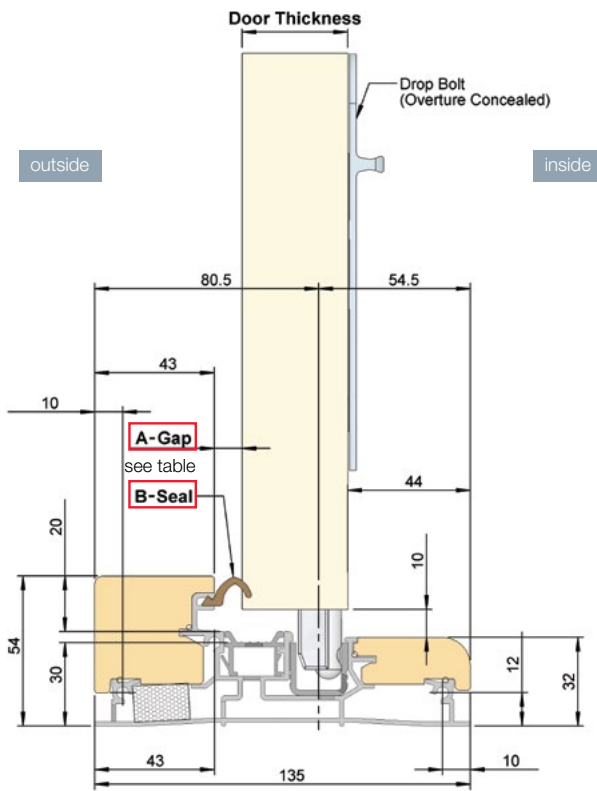

Door Thickness	A - Gap	B - Seal
38mm door thickness	10mm	E4QLS
40mm door thickness	8mm	E4QLS
42mm door thickness	6mm	AQ21

Outward concealed guide sill details

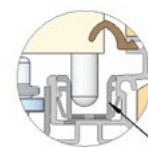
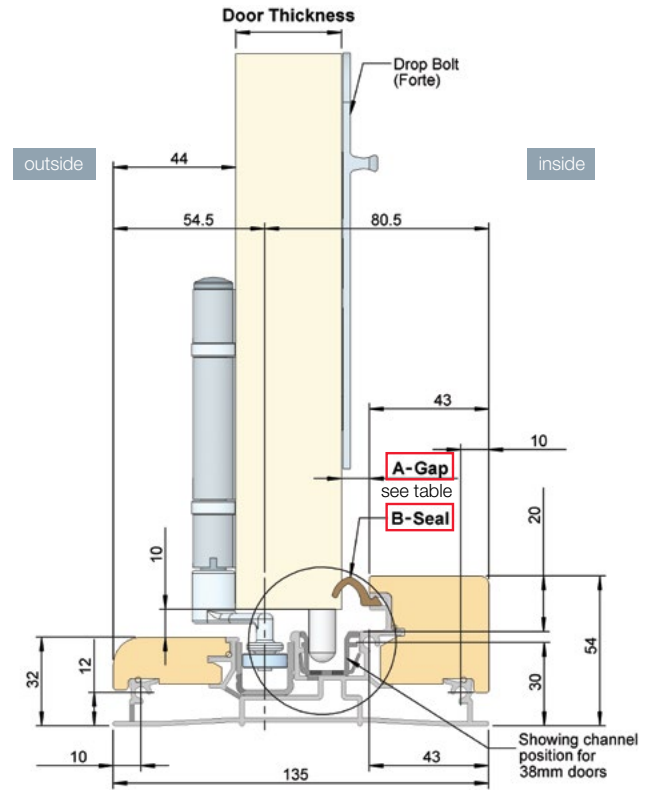

Showing channel position for 40mm doors (channel reversed)

Door Thickness	A - Gap	B - Seal
38mm door thickness	10mm	E4QLS
40mm door thickness	8mm	E4QLS

COMPONENT SELECTION

E3 is specified with 5 separate groups:

1. Track
2. Sill with Channel
3. Hardware
4. Weathersealing
5. Dropbolts

Components are required from all 5 groups to build an E3 folding door system.

Track

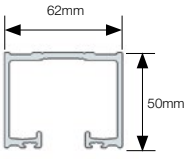
Part	Track	Product Code	Description
	Aluminium track, machined	E3TAM3N	3000mm, machined track, natural anodised
		E3TAM4N	4000mm machined track, natural anodised
		E3TAM57N	5700mm, machined track, natural anodised
		E3TAM3G	3000mm, machined track, gold anodised
		E3TAM4G	4000mm, machined track, gold anodised
		E3TAM57G	5700mm, machined track, gold anodised
	Aluminium Track non-machined	E3TA3N	3000mm, non-machined track, natural anodised
		E3TA4N	4000mm, non-machined track, natural anodised
		E3TA57N	5700mm, non-machined track, natural anodised
		E3TA3G	3000mm, non-machined track, gold anodised
		E3TA4G	4000mm, non-machined track, gold anodised
		E3TA57G	5700mm, non-machined track, gold anodised

Sill – outward concealed guide

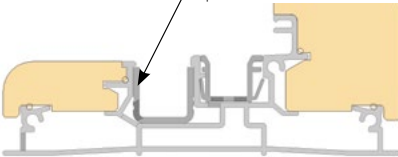
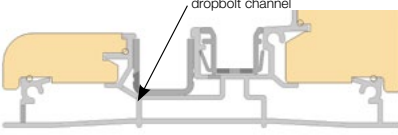
Parts	Product Code	Description
a) 	E2CS30NKWL	3000mm concealed sill with timber, natural anodised with kwila
	E2CS42NKWL	4200mm concealed sill with timber, natural anodised with kwila
b) 	E2CS48NKWL	4800mm concealed sill with timber, natural anodised with kwila
	E2CS57NKWL	5700mm concealed sill with timber, natural anodised with kwila

a) assembly for 38mm doors
 b) assembly for 40mm doors (dropbolt channel reversed)

COMPONENT SELECTION

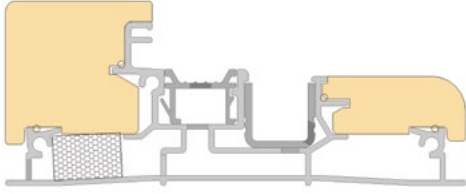

Sill – inward concealed guide

Parts	Product Code	Description
	E2CIS57NKWL	5700mm concealed external inward sill, natural anodised with kwila

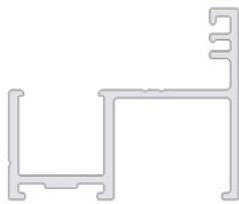
Sill – narrow concealed guide

Parts	Product Code	Description
	E2CNS4N	4000mm concealed narrow sill, natural anodised
	E2CNS57N	5700mm concealed narrow sill, natural anodised

Guide channels for concealed and straight hardware

Parts	Channel	Product Code	Description
	Poly guide channel 19mm H x 21mm W	E22FCP4	4000mm floor channel, polypropylene
		E22FCP57	5700mm floor channel, polypropylene
Aluminium retainer channel for concealed hardware			
	Aluminium retainer channel 22mm H x 24mm W	E22FCR4N	4000mm floor channel retainer, natural anodised
		E22FCR57N	5700mm floor channel retainer, natural anodised
		E22FCR4G	4000mm floor channel retainer, gold anodised
		E22FCR57G	5700mm floor channel retainer, gold anodised
Aluminium channel for straight hardware			
	Aluminium channel 19mm H x 26mm W	E2FCA4N	4000mm floor channel, natural anodised
		E2FCA57N	5700mm floor channel, natural anodised
		E2FCA4G	4000mm floor channel, gold anodised
		E2FCA57G	5700mm floor channel, gold anodised

COMPONENT SELECTION

Channel with poly insert for concealed hardware

Parts	Channel	Product Code	Description
	Concealed retainer and poly guide channel 22mm H x 24mm W	E22FCR4NP E22FCR57NP E22FCR4GP E22FCR57GP	4000mm floor channel retainer, natural anodised with poly channel 5700mm floor channel retainer, natural anodised with poly channel 4000mm floor channel retainer, gold anodised with poly channel 5700mm floor channel retainer, gold anodised with poly channel
Aluminium channel with insert			

Weatherseal

Part	Product Code	Description
Perimeter 	AQ21B AQ21L AQ21W	Aquamac 21 Schlegel Kerf seal, brown Aquamac 21 Schlegel Kerf seal, black Aquamac 21 Schlegel Kerf seal, white
Panel to panel 	AQ63B AQ63L	Aquamac 63 Schlegel Kerf seal, brown Aquamac 63 Schlegel Kerf seal, black
Access panel 	AQ109B AQ109L	Aquamac 109 Schlegel Kerf seal, brown Aquamac 109 Schlegel Kerf seal, black
Perimeter 	E4QLSB E4QLSW	Schlegel Q-lon perimeter weatherseal for 38 and 40mm doors, brown Schlegel Q-lon perimeter weatherseal for 38 and 40mm doors, white

“



*...easy flexibility of
modern design*







HARDWARE SELECTION

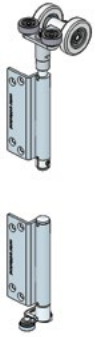

Right carrier set concealed

Parts	Parts on Panels	Product Code	Description
		E3CRCSS E3CRCSTG E3CRC SOL E3CRCSPC	concealed right hand carrier set, stainless steel concealed right hand carrier set, PVD Brass concealed right hand carrier set, PVD Bronze concealed right hand carrier set, custom powdercoat

Left carrier set concealed



Parts	Parts on Panels	Product Code	Description
		E3CLCSS E3CLCSTG E3CLCSOL E3CLCSPC	concealed left hand carrier set, stainless steel concealed left hand carrier set, PVD Brass concealed left hand carrier set, PVD Bronze concealed left hand carrier set, custom powdercoat

Right hand carrier set

Parts	Parts on Panels	Product Code	Description
		E3RCSS	right hand carrier set, stainless steel

HARDWARE SELECTION

Left hand carrier set

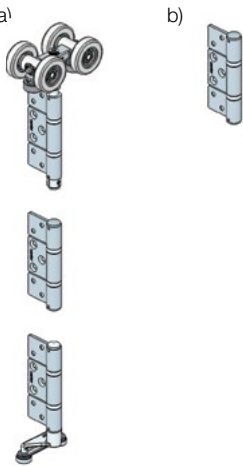
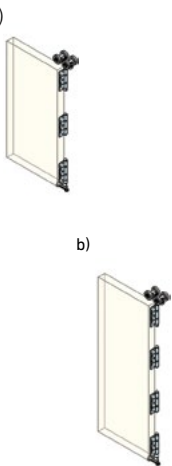

Parts	Parts on Panels	Product Code	Description
		E3LCSS	left hand carrier set, stainless steel

Intermediate carrier set concealed (fourth hinge recommended for doors over 2250mm)

Parts	Parts on Panels	Product Code	Description
		E3CICSS E3CICSTG E3CICSOL E3CICSPC E3HNHS E3HNHTG E3HNHOL E3HNHPC	concealed intermediate set, stainless steel concealed intermediate set, PVD Brass concealed intermediate set, PVD Bronze concealed intermediate set, custom powdercoat single straight hinge, stainless steel single straight hinge, PVD Brass single straight hinge, PVD Bronze single straight hinge, custom powdercoat

a) intermediate carrier set with concealed bottom guide
 b) fourth hinge recommended for doors over 2250mm

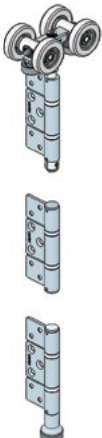
Intermediate carrier set

Parts	Parts on Panels	Product Code	Description
		E3ICSS	intermediate carrier set, stainless steel

HARDWARE SELECTION

Hinge set

Parts	Parts on Panels	Product Code	Description
<p>a)</p> <p>b)</p>	<p>a)</p> <p>b)</p>	<p>E3HSS E3HSTG E3HSOL E3HSPC</p> <p>E3HNHSS E3HNHSTG E3HNHSOL E3HNHSPC</p>	<p>hinge set with handle, stainless steel hinge set with handle, PVD Brass hinge set with handle, PVD Bronze hinge set with handle, custom powdercoat</p> <p>hinge set no handle, stainless steel hinge set no handle, PVD Brass hinge set no handle, PVD Bronze hinge set no handle, custom powdercoat</p>

a) hinge set with handle for outward doors
b) hinge set no handle for inward doors

Single hinge

Parts	Product Code	Description
	<p>E3HNHS E3HNHTG E3HNHOL E3HNHPC</p>	<p>single straight hinge, stainless steel single straight hinge, PVD Brass single straight hinge, PVD Bronze single straight hinge, custom powdercoat</p>
	<p>E3HS</p>	<p>single straight hinge with handle, stainless steel</p>

HARDWARE SELECTION

Half offset hinge set

Parts	Parts on Panels	Product Code	Description
<p>a) </p> <p>b) </p>	<p>a) </p> <p>b) </p>	<p>E3HHSS E3HHSTG E3HHSOL E3HHSPC</p> <p>E3HHNHSS E3HHNHSTG E3HHNH SOL E3HHNHSPC</p>	<p>half offset hinge set with handle, stainless steel half offset hinge set with handle, PVD Brass half offset hinge set with handle, PVD Bronze half offset hinge set with handle, custom powdercoat</p> <p>half offset hinge set no handle, stainless steel half offset hinge set no handle, PVD Brass half offset hinge set no handle, PVD Bronze half offset hinge set no handle, custom powdercoat</p>

a) half offset hinge set with handle for outward doors
b) half offset hinge set with no handle for inward doors

Single half offset hinge

Parts	Product Code	Description
	<p>E3HHNHSS E3HHNHSTG E3HHNHOL E3HHNHPC</p>	<p>single half offset hinge, stainless steel single half offset hinge, PVD Brass single half offset hinge, PVD Bronze single half offset hinge, custom powdercoat</p>
	<p>E3HHS</p>	<p>single half off set hinge with handle, stainless steel</p>

HARDWARE SELECTION

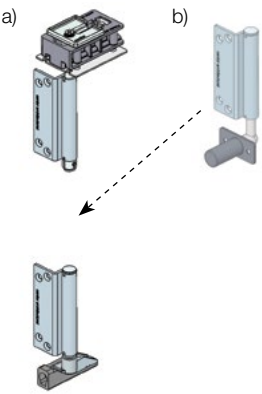
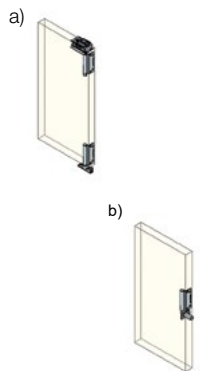

Pivot set – wall pivot

Parts	Parts on Panels	Product Code	Description
 <p>a) pivot set</p> <p>b) jamb mounted middle wall pivot</p>	 <p>a)</p> <p>b)</p>	<p>E3CPSS E3CPSTG E3CPSOL E3CPSPC</p> <p>E3WPSS E3WPSTG E3WPSOL E3WPSPC</p>	<p>concealed pivot set, stainless steel concealed pivot set, PVD Brass concealed pivot set, PVD Bronze concealed pivot set, custom powdercoat</p> <p>wall pivot set, stainless steel wall pivot set, PVD Brass wall pivot set, PVD Bronze wall pivot set, custom powdercoat</p>

a) pivot set

b) jamb mounted middle wall pivot recommended for doors over 2250mm to central deflection and bowing

External handle

Parts	Parts on Panels	Product Code	Description
		<p>E3EHS E3EHTG E3EHOL E3EHPC</p>	<p>external handle, stainless steel external handle, PVD Brass external handle, PVD Bronze external handle, custom powdercoat</p>

single hinge with handle for outward and inward application (please refer to Common Panel Layouts page 25 for more details)

DOOR SIZE CALCULATOR

To calculate the dimensions of the doors or openings we strongly recommend using Centor’s “Doorcalc” program, which is a Microsoft Excel spreadsheet. To manually calculate door sizing for an opening, follow the following steps:

1. Prepare a basic sketch of your door opening (see worked example), to visualise clearances and check sizes
2. The calculation is based on all panels being equal width, using half-offset hinges (Patent Pending). Note that the allowance between each panel is 4mm although hinge thickness is less - this allowance has been determined by consultation with fabricators as the best approximation for calculation. Clearance between hinges and hinge pins, coupled with the pressure from compression seals accounts for the allowance being larger than the nominal hinge flap thickness.
3. Recommended clearances are as follows;

- Jamb to panel (door closed) 7mm
- Panel to panel (door closed) 4mm
- Top of panel to head 6mm
- Bottom of panel to sill 10mm for concealed guides

4. Panel width is:

$$W = \frac{L - 14 - (4 \times (N-1))^{**}}{N}$$

- Panel width W
- Opening width L
- Total number of panels N

Worked Examples

Clear opening size 2425 high x 4200 wide (L), and a 3L x 2R arrangement.

$$W = \frac{4200 - 14 - (4 \times (5-1))}{5}$$

$$W = 834\text{mm}$$

Check against your door layout:

$$W = 2(7.0) + 4(4) + 5(834) = 4200 \text{ (OK)}$$

The panel height is the opening height less the nominal top and bottom clearances:

$$\text{Panel Height } H = 2425 - 5 - 10 = 2410\text{mm}$$

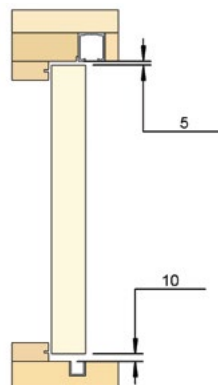

** Note: for even sets, eg. 2L2R or 4L2R, the meeting gap would be larger - double seals are used to close the gap.

$$W = \frac{L - 14 - (4 \times N)}{N}$$

COMMON PANEL LAYOUTS

Hardware Legend			
PS	pivot set	HHS	half offset hinge set
WPS	wall pivot set	HS	hinge set (flat)
ICS	intermediate carrier set	EH	external handle
LCS	left carrier set	DB	dropbolt
RCS	right carrier set		

Legend	
Passage set Handles/Lock sets refer to Centor Door Furniture at centor.com	
Dropbolts top and bottom	

Note: Wall Pivot Set recommended for doors over 2250mm in height

Floating Door Pairs	
	Per pair of doors 1x left carrier set 1x right carrier set 1x hinge set 2x dropbolt

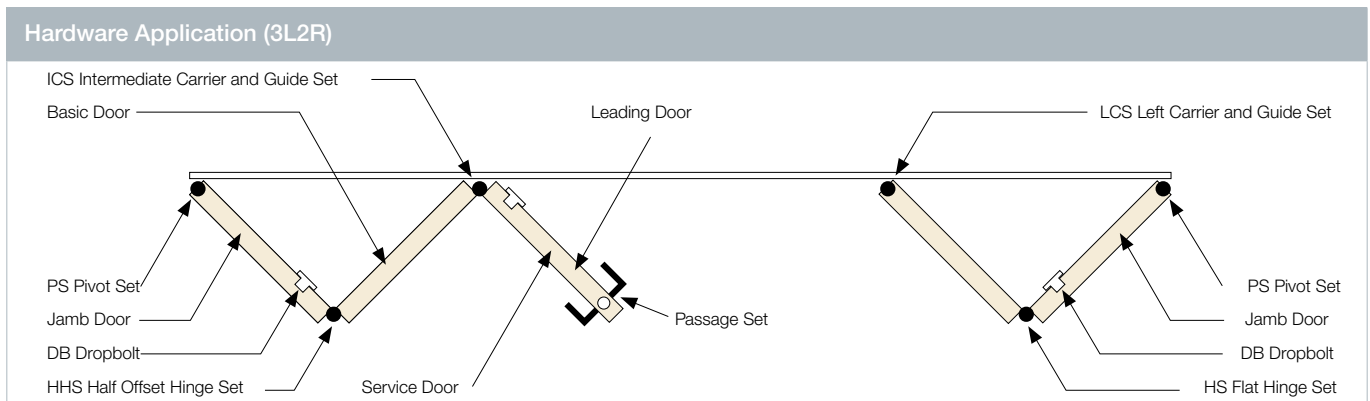

Outward Application Exterior Handle Option

Use one exterior handle on exit door (outward system) where passage set/lock not required. Use dropbolts top and bottom to lock door from the inside only.

Note: Exit door not accessible from exterior in this application.

Inward Application Exterior Handle Option

Use one exterior handle on each pair of doors (inward system) to pull open and close doors

COMMON PANEL LAYOUTS

Any panel combination up to 8 in each direction is possible

Code	Opening Configuration	Hardware
2L		<ul style="list-style-type: none"> 1x pivot set 1x wall pivot set* 1x right carrier set 1x hinge set 2x dropbolt or 1x twinpoint lock
2L1R		<ul style="list-style-type: none"> 2x pivot set 2x wall pivot set* 1x right carrier set 1x hinge set 2x dropbolt or 1x twinpoint lock
3L		<ul style="list-style-type: none"> 1x pivot set 1x wall pivot set* 1x intermediate carrier set 1x half offset hinge set 2x dropbolt or 1x twinpoint lock
3L1R		<ul style="list-style-type: none"> 2x pivot set 2x wall pivot set* 1x intermediate carrier set 1x half offset hinge set 4x dropbolt
4L		<ul style="list-style-type: none"> 1x pivot set 1x wall pivot set* 1x intermediate carrier set 1x right carrier set 2x half offset hinge set 4x dropbolt or 2x twinpoint lock
4L1R		<ul style="list-style-type: none"> 2x pivot set 2x wall pivot set* 1x intermediate carrier set 1x right carrier set 2x half offset hinge set 4x dropbolt or 2x twinpoint lock
3L2R		<ul style="list-style-type: none"> 2x pivot set 2x wall pivot set* 1x intermediate carrier set 1x left carrier set 1x hinge set 1x half offset hinge set 4x dropbolt or 2x twinpoint lock
5L		<ul style="list-style-type: none"> 1x pivot set 1x wall pivot set* 2x intermediate carrier set 1x hinge set 1x half offset hinge set 4x dropbolt or 2x twinpoint lock
3L3R		<ul style="list-style-type: none"> 2x pivot set 2x wall pivot set* 2x intermediate carrier set 2x half offset hinge set 6x dropbolt

*Wall Pivot Set required for doors over 2250mm

COMMON PANEL LAYOUTS

Any panel combination up to 8 in each direction is possible

Code	Opening Configuration	Hardware
7L		<ul style="list-style-type: none"> 1x pivot set 1x wall pivot set* 3x intermediate carrier set 2x hinge set 1x half offset hinge set 6x dropbolt or 3x twinpoint lock
4L3R		<ul style="list-style-type: none"> 2x pivot set 2x wall pivot set* 2x intermediate carrier set 1x right carrier set 3x half offset hinge set 6x dropbolt or 3x twinpoint lock
5L2R		<ul style="list-style-type: none"> 2x pivot set 2x wall pivot set* 2x intermediate carrier set 1x left carrier set 2x hinge set 1x half offset hinge set 6x dropbolt or 3x twinpoint lock
5L3R		<ul style="list-style-type: none"> 2x pivot set 2x wall pivot set* 3x intermediate carrier set 1x hinge set 2x half offset hinge set 8x dropbolt
2R		<ul style="list-style-type: none"> 1x pivot set 1x wall pivot set* 1x left carrier set 1x hinge set 2x dropbolt or 1x twinpoint lock
1L2R		<ul style="list-style-type: none"> 2x pivot set 2x wall pivot set* 1x left carrier set 1x hinge set 2x dropbolt or 1x twinpoint lock
3R		<ul style="list-style-type: none"> 1x pivot set 1x wall pivot set* 1x intermediate carrier set 1x half offset hinge set 2x dropbolt or 1x twinpoint lock
1L3R		<ul style="list-style-type: none"> 2x pivot set 2x wall pivot set* 1x intermediate carrier set 1x half offset hinge set 4x dropbolt
2L2R		<ul style="list-style-type: none"> 2x pivot set 2x wall pivot set* 1x right carrier set 1x left carrier set 2x hinge set 4x dropbolt or 2x twinpoint lock

*Wall Pivot Set required for doors over 2250mm

COMMON PANEL LAYOUTS

Any panel combination up to 8 in each direction is possible

Code	Opening Configuration	Hardware
1L4R		<ul style="list-style-type: none"> 2x pivot set 2x wall pivot set* 1x intermediate carrier set 1x left carrier set 2x half offset hinge set 4x dropbolt or 2x twinpoint lock
4R		<ul style="list-style-type: none"> 1x pivot set 1x wall pivot set* 1x intermediate carrier set 1x left carrier set 2x half offset hinge set 4x dropbolt or 2x twinpoint lock
2L3R		<ul style="list-style-type: none"> 2x pivot set 2x wall pivot set* 1x intermediate carrier set 1x right carrier set 1x hinge set 1x half offset hinge set 4x dropbolt or 2x twinpoint lock
5R		<ul style="list-style-type: none"> 1x pivot set 1x wall pivot set* 2x intermediate carrier set 1x hinge set 1x half offset hinge set 4x dropbolt or 2x twinpoint lock
3L4R		<ul style="list-style-type: none"> 2x pivot set 2x wall pivot set* 2x intermediate carrier set 1x left carrier set 3x half offset hinge set 6x dropbolt or 3x twinpoint lock
7R		<ul style="list-style-type: none"> 1x pivot set 1x wall pivot set* 3x intermediate carrier set 2x hinge set 1x half offset hinge set 6x dropbolt or 3x twinpoint lock
2L5R		<ul style="list-style-type: none"> 2x pivot set 2x wall pivot set* 2x intermediate carrier set 1x right carrier set 2x hinge set 1x half offset hinge set 6x dropbolt or 3x twinpoint lock
8R		<ul style="list-style-type: none"> 1x pivot set 1x wall pivot set* 3x intermediate carrier set 1x left carrier set 2x hinge set 2x half offset hinge set 8x dropbolt or 4x twinpoint lock

*Wall Pivot Set required for doors over 2250mm

SURELOCK ADJUSTMENT™

Centor's upgraded Surelock™ technology (Surelock 5) ensures folding doors running on E2 and E3 hardware can be adjusted simply with an 8mm hex key.

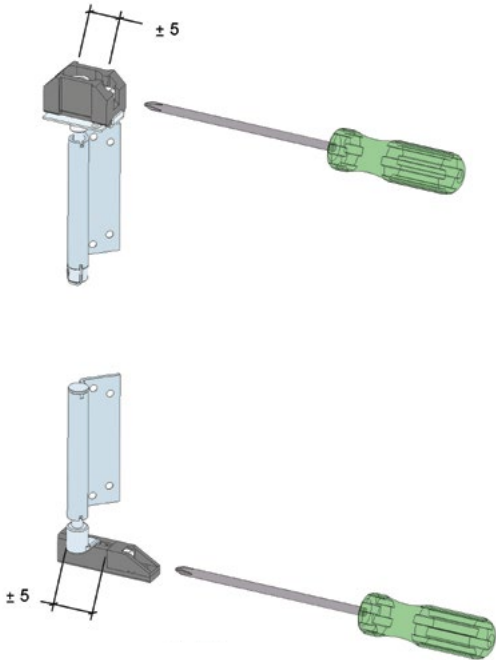
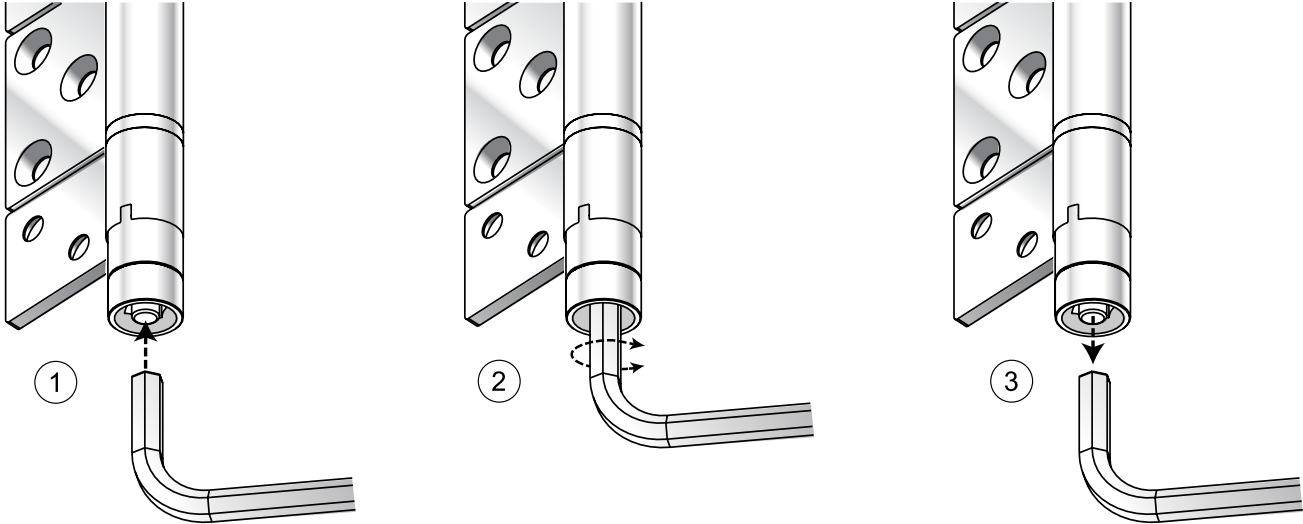

Patents Apply



Centor Australia Pty Ltd

1300 CENTOR (1300 236 867)

+61 7 3868 5777

mail@centor.com.au

centor.com

